

ELEVATION N . scale 1/2" = 1' - 0"

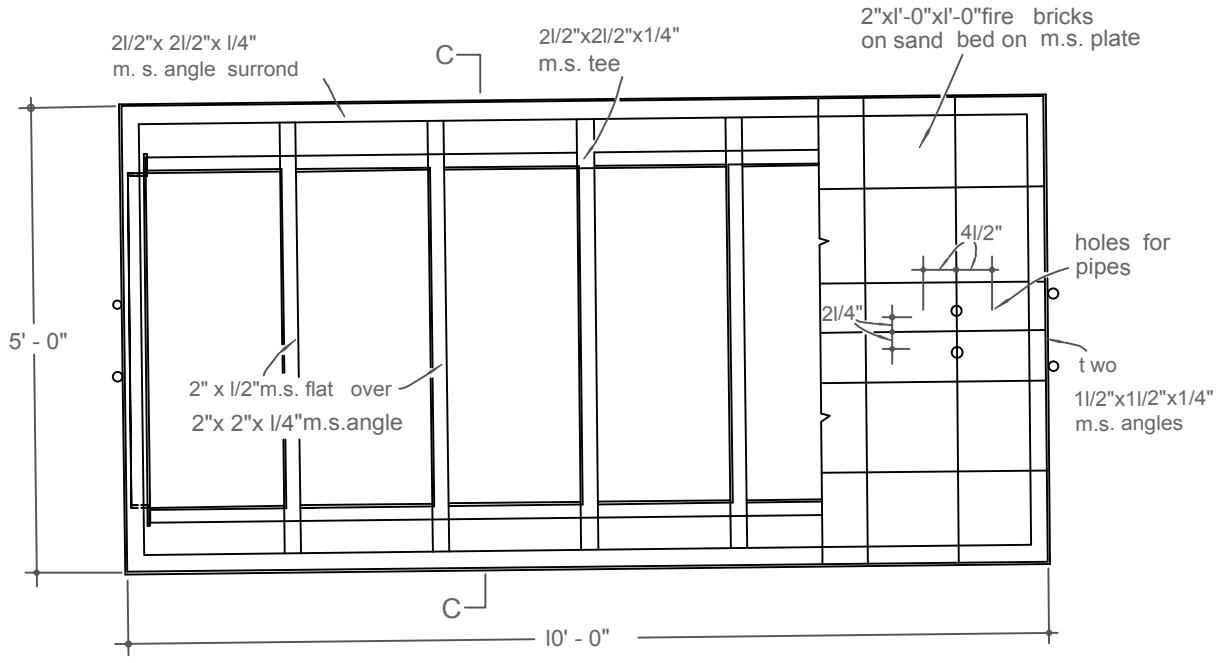

PLAN AT A - A. scale 1/2" = 1' - 0"

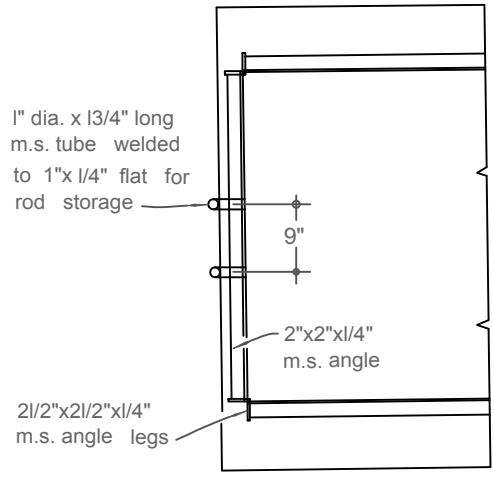

PLAN AT B - B. scale 1/2" = 1' - 0"

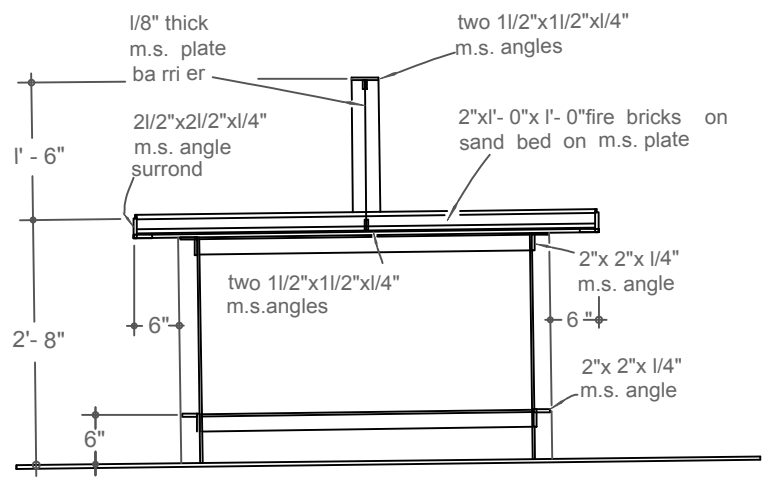

SECTION C - C. scale 1/2" = 1' - 0"